

Owners Manual

Öhlins shock absorbers ATV



Including:

Safety

Design
features

Basic
adjustments

Technical
information



Safety signals

Important information concerning safety is distinguished in this manual by the following notations:



The Safety alert symbol means:
Caution! Your safety is involved.

WARNING!

Failure to follow warning instructions could result in **severe or fatal injury** to anyone working with, inspecting or using the suspension, or to bystanders.

CAUTION!

Caution indicates that special precautions must be taken to avoid damage to the suspension.

NOTE!

This indicates information that is of importance with regard to procedures.

Introduction

All of Öhlins advanced suspension products are adapted to the brand and model. This means that length, travel springaction and damping characteristics, are tested individually just for the vehicle that you have decided to fit with Öhlins suspension.

Before installation

Öhlins Racing AB can not be held responsible for any damage whatsoever to shock absorber or vehicle, or injury to persons, if the instructions for fitting and maintenance are not followed exactly.

Similarly, the warranty will become null and void if the instructions are not adhered to.

Contents

Safety signals	2
Tuning the suspension	3
Design	3
Function	4
Compression damping	4
Rebound damping	4
Settings	5
Preload adjustment	6
Setting the damping	7
Setting your vehicle:	7
Start with rebound damping	8
Compression damping	8
Inspection and maintenance	9

WARNING!

1. *Installing a shock absorber, that is not approved by the vehicle manufacturer, may affect the stability of your vehicle. Öhlins Racing AB cannot be held responsible for any personal injury or damage whatsoever that may occur after fitting the shock absorber. Contact an Öhlins dealer or other qualified person for advice.*

2. *Please study and make certain that you fully understand all the mounting instructions and the owners manuals before handling this shock absorber kit. If you have any questions regarding proper installation procedures, contact an Öhlins dealer or other qualified person.*

3. *The vehicle service manual must be referred to when installing the Öhlins shock absorber*

NOTE!

Öhlins products are subject to continual improvement and development. Consequently, although these instructions include the most up-to-date information available at the time of printing, there may be minor differences between your suspension and this manual. Please consult your Öhlins dealer if you have any questions with regard to the contents of the manual.

© Öhlins Racing AB.

All rights reserved.

Any reprinting or unauthorized use without the written permission of Öhlins Racing AB is prohibited.

Printed in Sweden.

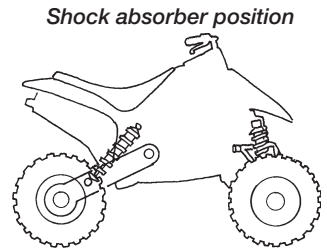
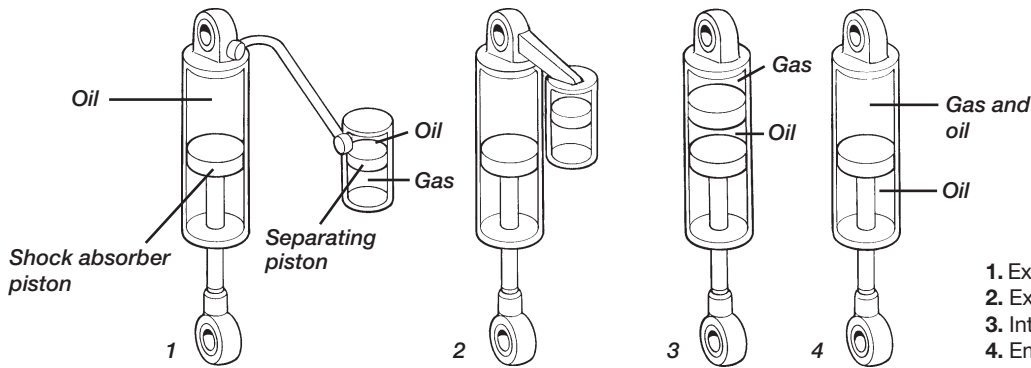

1. External reservoir with hose connection
2. External piggyback reservoir
3. Internal gas reservoir
4. Emulsion shock absorber

Tuning the suspension

Road holding qualities

All vehicles are designed with a suspension geometry that includes wheel movements and angles. The changing of components can affect this and it is therefore essential that both the rear and the front ends match each other.

Changing to Öhlins suspension gives optimum performance only when both the front and the rear suspension interact properly. It is of greatest importance that the front and rear loaded height (ride height sag) are within the specified values in the Mounting instructions.

Design

Most of Öhlins suspensions are of the De Carbon type. The fluid is put under gas pressure and the gas and the fluid are kept apart by a separating piston. The separating piston is often fitted in a separate fluid reservoir, connected by hose (Fig.1) or fixed direct on top of the shock absorber (Fig.2) (piggyback).

There are also models where the separating piston is fitted inside the main shock absorber (Fig.3) (internal gas reservoir). Öhlins even manufacture a small number of emulsion shock absorbers that do not have a separating piston (Fig.4).

Pressurization of the fluid is made with nitrogen. The pressurization prevents cavitation of the fluid and the shock absorbing action is therefore more even. The external fluid reservoirs also contribute to better cooling of the fluid, giving longer service life to both the fluid and components.

Öhlins shock absorbers have integrated temperature compensation. As the temperature increases and the fluid flows more easily the flow

is controlled accordingly. The shock absorbing effect is therefore independent of the temperature.

Öhlins shock absorbers provide the possibility for adjustment, making them adaptable to most vehicles, drivers and ranges of use. All of the shock absorbers, equipped with springs, have adjustable preloading of the spring action. The more advanced models permit individual adjustment of compression damping and rebound damping.

WARNING!

All vehicles are designed with a suspension geometry that includes wheel movements and angles. The changing of components can affect this and it is therefore essential that both the rear and the front ends match each other. Changing to Öhlins suspension gives optimum performance only when both the front and the rear suspension interact properly.

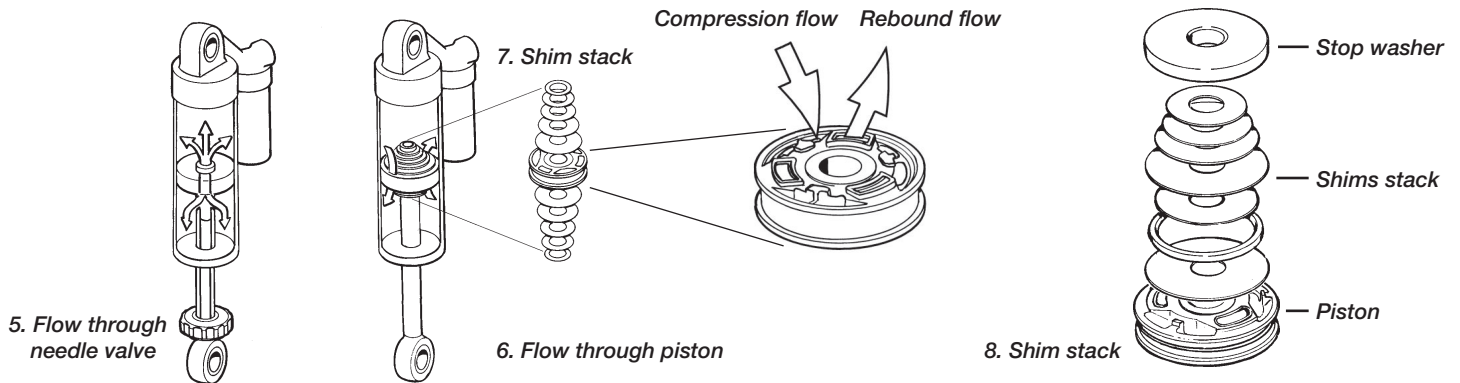

Function

The function, in principle, is that fluid is forced through needle valves at a low rate of flow (Fig.5) and through a number of apertures in the piston at a high rate of flow (Fig.6). The flow through these apertures is regulated by shims (thin steel washers) that at high pressure are deflected to open for the fluid (Fig.7). On some models the needle valves can be set individually (illustration).

By altering the size of the shims-stack (ie, number, thickness, diameter) (Fig.8) the characteristics of the damping action can be varied (this shall only be done by Öhlins authorized service workshops).

Compression damping

When movement of the vehicle causes compression in the shock absorber, the fluid flows through the needle valve (combined compression and return valve) in the piston rod. If velocity of the piston is high, ie, in the case of rapid compression, this will not be sufficient and consequently the shims underneath the piston will open to allow a greater rate of flow.

The fluid that is displaced by the volume of the piston rod is forced into the external fluid chamber via a separate compression valve. Even this valve is fitted with shims that open at high piston velocity. The separating piston is displaced, thus increasing the gas pressure.

Rebound damping

When the spring presses the shock absorber out again, the fluid flows back through the needle valve in the piston rod. The fluid flowing into the chamber is forced by the pressure of the gas back into the shock absorber via a separate non return valve. If velocity of the piston is high, the shims on top of the piston will also open to allow the fluid to flow through.

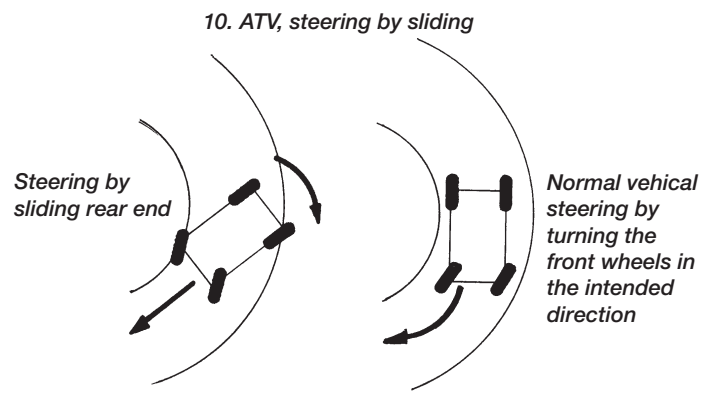
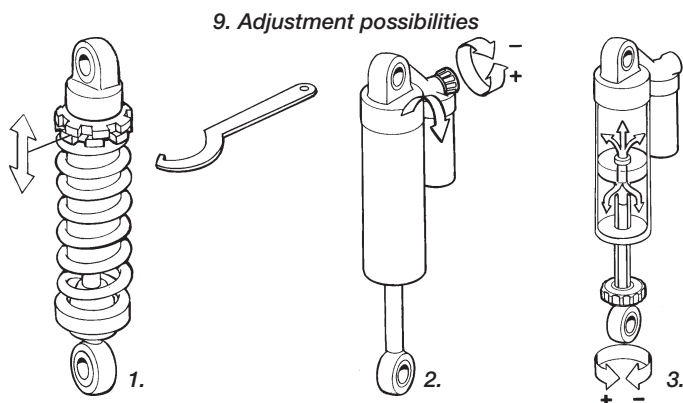

Settings

Basic settings

Always ensure that the basic setting made by Öhlins is correct. It is adapted to the specific make and model (in its original state) and for a rider of average weight.

These adjustments are made to optimize the suspension: (Fig.9)

1. **SPRING PRELOAD** is when you adjust the spring to match your body weight and weight of your equipment.
2. **COMPRESSION DAMPING** controls how fast the shock absorber compresses when you hit a bump.
3. **REBOUND DAMPING** controls how fast the shock absorber returns to its normal position after it has been compressed.

As an ATV has a rear axle without differential it is forced to turn mostly by sliding (Fig.10). Therefore excessively good road holding capabilities is undesirable. The rear end must be able to easily break loose to slide and the front wheels must not have too sharp turning radius, as this could cause the ATV to flip over.

The tires are also a very important factor to the ATV's road holding capabilities. Pattern, sidewall flexibility and air pressure affects these characteristics. Changing the dimensions of A-arms, swing arm and linkage will also affect the vehicle's abilities.

Because of this it is vital that the suspension is adjustable. Any change of components will demand different settings.

To complicate the situation, the technique and skill of the driver will affect the performance of the machine.

Therefore it is extremely hard to recommend specific settings. The best recommendation is to proceed by trial and error.

However, good understanding of suspension design and function will give you the best chance to take advantage of the adjustment possibilities. This is why we only give basic and simple advice on how to set the dampers/shock absorber.

Read the manual carefully and start your work. The Öhlins shock absorber will give you all possibilities for fine adjustment to fit your personal desire.

⚠ WARNING!

1. ATVs are extremely depending on which kind of tires are being used. Soft versus hard tires can completely alter the road holding abilities. The suspension must be tuned in after each change of tires.
2. Every change in suspension geometry, i.e. change of a-arms etc, must be followed by new settings of the shock absorbers.

11. Measuring of ride height sag

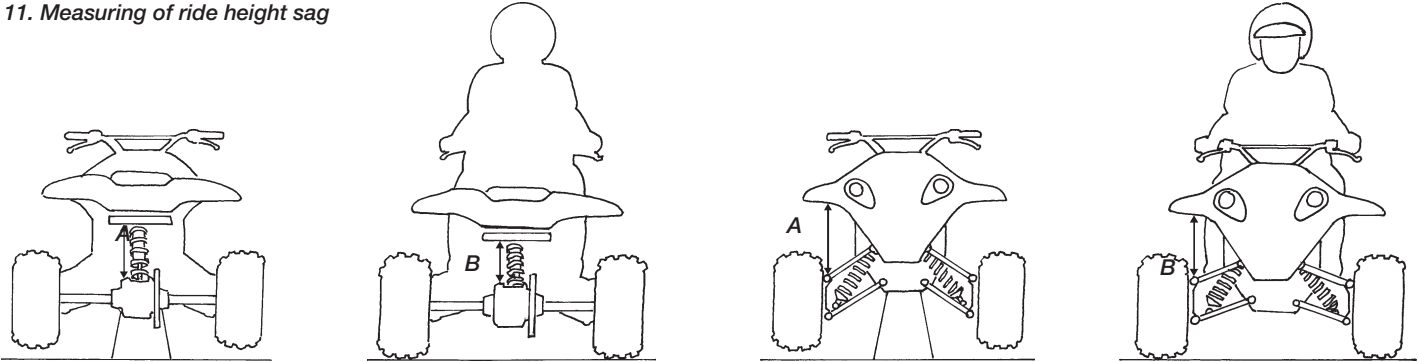

Preload Adjustment

Setting the spring preload, adjusting procedures:

By turning the rings on the shock absorber body you can adjust the springs tension to suit your weight. Hold the upper ring and adjust the lower one to the desired position. Then lock with the upper ring. To make this adjustment properly you must measure the ride height sag (Fig.11).

⚠ WARNING!

Preload on the spring/springs is very important, because it affects the height of the vehicle and the wheel angles. Consequently, road holding characteristics can be changed, even negatively.

NOTE!

For very light or very heavy drivers, spring change may be needed to receive correct spring preload.

Rear end

1. Lift the rear wheels up off the ground.
2. With the wheels off the ground, measure the distance from the top center of the rear axle to a point straight above it on the frame of the ATV. (A)
3. Wear all your riding gear. Sit on the seat with your feet on the pegs in correct riding position. Have someone to repeat the measuring procedure (B). The difference between the first and the second measurement ride height sag (A-B).

4. Adjust your spring preload so that your ride height sag is within the limits below or are according to the recommended settings in your Mounting instructions.

Front end

Use the same procedure to measure the sag for the front end. Adjust the spring preload to recommended settings.

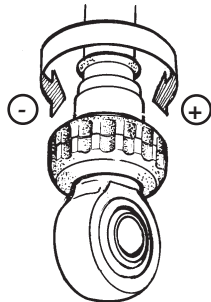

12. Rebound damper adjuster

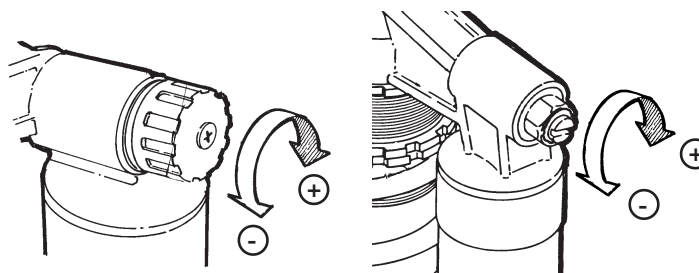

13. Compression damping adjusters

⊕ = more damping
⊖ = less damping

Setting the damping

The adjusting possibilities of the advanced Öhlins shock absorbers facilitate fine setting. You can optimize adjustments to suit your own vehicles weight and equipment, your individual way of driving and the condition of the road. To be able to improve the road holding qualities it is of the utmost importance that you fully understand the functioning of the shock absorbers. Then you can learn by trial and error how they affect the vehicle.

Depending on the model there are adjustments for rebound damping and compression damping. They have a normal right-hand thread. By turning clockwise they increase the damping action and counterclockwise they reduce it, see illustrations above. The knobs has definite positions with a noticeable "click", so it is easy to count to the right setting.

Rebound damping action affects the characteristics of the vehicle most. The setting knob is

located at the bottom on the piston rod (Fig.12). It can be adjusted in about 40 steps.

Compression damping is set with a knob or a screw on top of the external reservoir (Fig.13). This can be adjusted in about 25 steps.

NOTE!

When making new adjustments it is easiest to go fully closed and then count forward to the new setting. The adjusting knobs should not be turned in too hard. Use fingers only when possible. The adjustment should be made when the shock absorber is cold.

NOTE!

If no "click" is felt, the shock absorber must be inspected by an authorized service workshop. It could be due to incorrect or lack of gas pressure.

Setting your vehicle

NOTE!

Always begin with the basic settings recommended by Öhlins. Always make notes, adjust in small steps and make only one adjustment at a time. Adjustments should be made in small steps (few clicks) at a time.

By utilizing the adjustment possibilities you can test by trial and error, and learn how they affect your vehicle.

Always begin by test driving with all adjustments at their basic setting. Choose a short run of varying character, ie, long and sharp bends, hard and soft bumps. Keep to the same run and make only one adjustment at a time.

14. Rebound damping

15. Compression damping

- Unstable
- Loose
- Bouncy

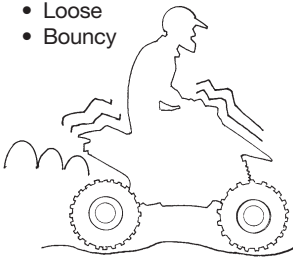

Increase

- Hard
- Bumpy

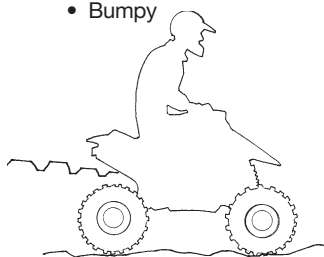

Reduce

- Soft
- Low
- Bottom

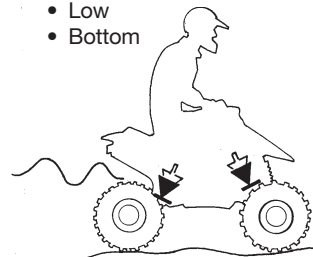

Increase

- Harsh
- Hard

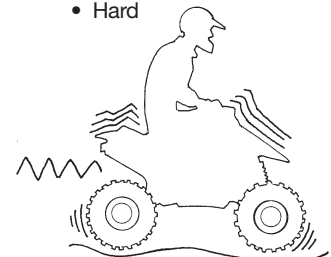

Decrease

Start with the rebound damping (Fig.14)

If the vehicle feels unstable, loose and rather bouncy then the rebound damping should be increased. Begin by turning the adjusting knob 4 steps (clicks) clockwise, according to page 7. Test run again and adjust two steps back if it feels too hard and bumpy.

If the vehicle is hard and bumpy, especially over a series of bumps, then the rebound damping should be reduced. Turn counter-clockwise 4 steps, test run and make any necessary correction by 2 steps.

Compression damping (Fig.15)

If the vehicle feels soft, has low riding position and a tendency to bottom easily in long dips then the compression damping should be increased. Screw clockwise 4 steps and test run again. If this was too much then turn back two steps (counter-clockwise).

If the vehicle feels harsh and has hard resilience, e.g., over changes in the riding surface, then the compression damping must be reduced. Turn anticlockwise 4 steps. Test run and make any necessary correction to two steps.

When you have sufficient feel of the vehicle then you can make further fine adjustments. It is feeling and experience that counts.

NOTE!

Ensure that the springs are properly preloaded before attempting to make any adjustments. A simple rule is that increased preload of the spring should be followed by an increase of rebound damping.

When you feel that you have achieved an improvement, go back to where you started and check once more. Be observant of other relevant factors such as tires, temperature, etc. Test run to make sure whether further fine adjustment should be made.

⚠ WARNING!

Never alter gas pressure. Special purpose charging equipment and access to a nitrogen source is required. The gas pressure should normally never be altered.

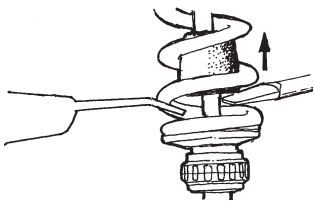

16. Lift the bump rubber and clean the area below.

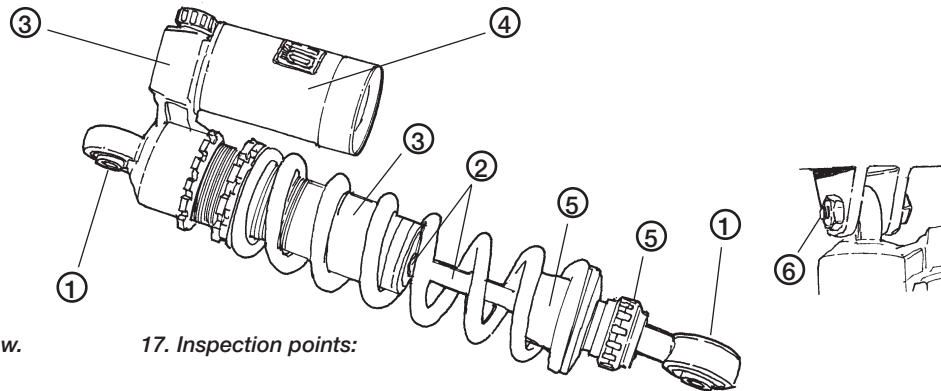

17. Inspection points:

Inspection and maintenance

Clean the shock absorbers externally with a soft detergent . Use compressed air . Be careful that all dirt and debris is removed.

Lift the bump rubber and clean the area below (Fig.16).

Keep the shock absorbers clean and always spray them with oil (QS 14, WD40 or CRC 5-56 or similar) after washing the vehicle.

CAUTION!

Never use detergents that can damage the surfaces of the shock absorber. Use of thinner and brake cleaner will dry the surfaces too much..

Inspection points: (Fig.17)

1. Check ball joints for possible excessive play.
2. Check the piston shaft for leakage and damage.
3. Check the shock absorber body and for external damages.
4. Check the external reservoir for damages that can restrict the floating piston from moving freely.
5. Excessive wear of rubber components
6. Fastening to the vehicle

Preventive maintenance and regular inspection reduces the risk of functional disturbance. If there is any need for additional service, please get in touch with an authorised Öhlins service workshop. There they have the necessary tools and know-how for whatever you need.

Recommended inspection and maintenance intervals:

Normal use	2 - 3 times a year
Race track	Every ten hours

Once a year, general:

Change shock absorber oil.
Use Öhlins shock absorber oil only.

NOTE!

Make certain that your shock absorber are always filled with Öhlins High performance shock absorber oil

Product guide

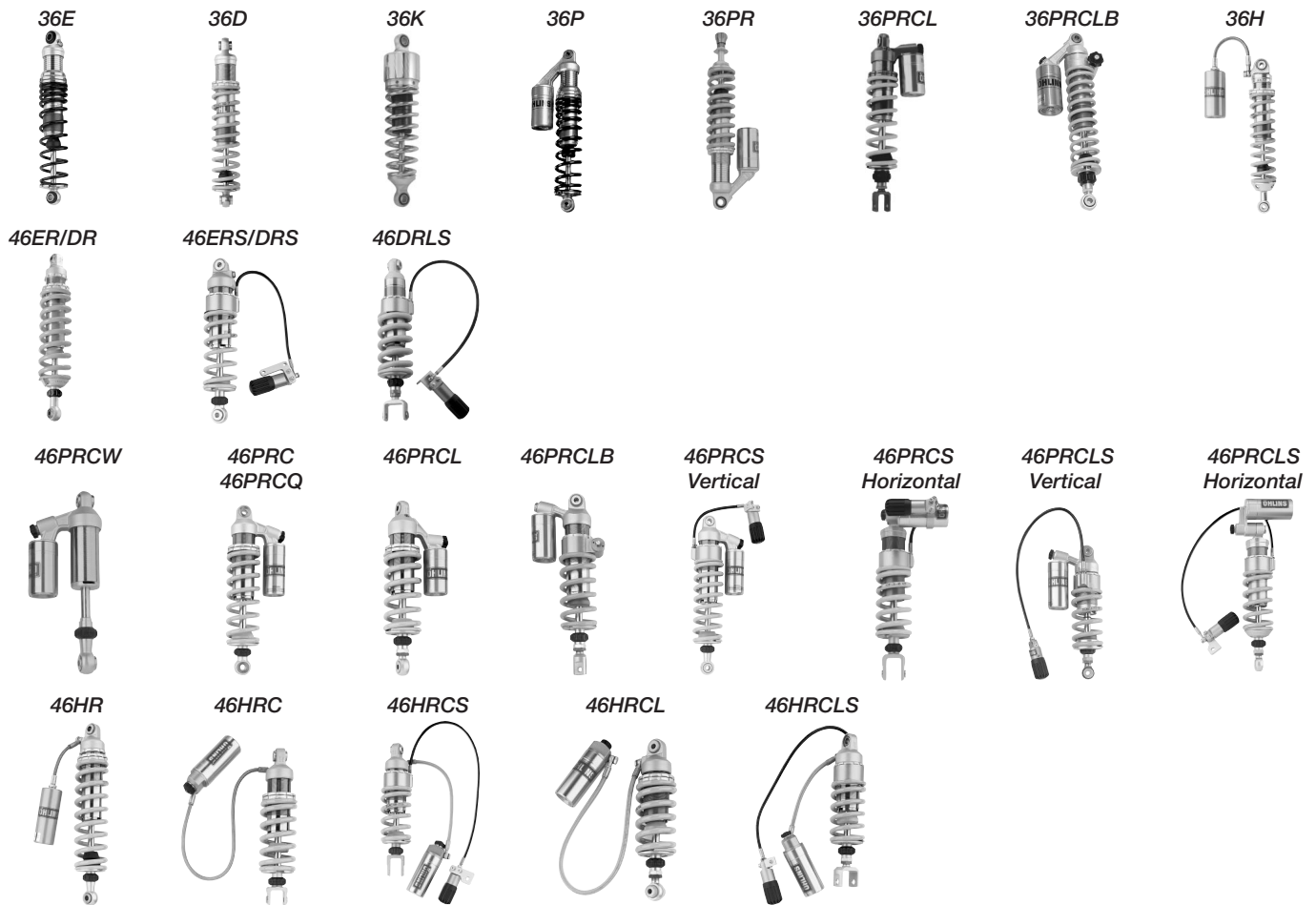

Shock absorber type

36, 46

Piston diameter in mm.

E

Emulsion type of shock absorber.

D

De Carbon type of shock absorber with internal reservoir in the main body.

P

De Carbon type of shock absorber with external "piggy back" reservoir.

H

De Carbon type of shock absorber with hose mounted external reservoir.

W

Shock absorber delivered without spring.

K

Emulsion type of shock absorber for cruiser bikes.

Q

Progressive damping shock absorber with two pistons.

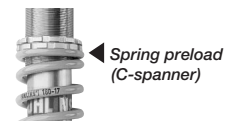
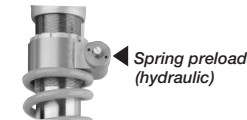
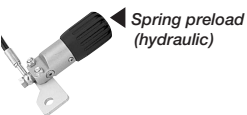
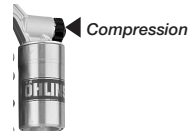

Adjustment features

C

Adjustable compression damping.

Adjuster wheel on the reservoir.

R

Adjustable rebound damping.

Adjuster wheel on the piston shaft above the end eye.

S

Hose mounted hydraulic spring preload adjuster.

Adjuster wheel on the hose.

B

Integrated hydraulic spring preload adjuster.

Adjuster wheel on the adjuster.

L

Adjustable length.

Adjuster nuts above the end eye.

NOTE!

Your shock absorber may look different from the one pictured.
 On type 46P the compression adjustment knob sometimes is a screw.
 The reservoir could be angled to fit your bike and a horizontal reservoir is used on some models.

Steering dampers

Road & Track



Road & Track kits

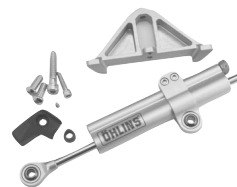

MX & Enduro



Front fork springs

Road & Track, MX & Enduro

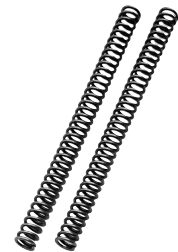

Front forks

MX & Enduro, Road & Track Superbike & RR



Front fork fluids

Road & Track, MX & Enduro



Notes



Öhlins Racing AB, Box 722, S-194 27 Upplands Väsby, Sweden.
Phone +46 8 590 025 00, fax +46 8 590 025 80.
E-mail: info@ohlins.se
www.ohlins.com